

Multilayer Ceramic Chip Capacitors for High Temperature Applications  
[High Temperature Stacked Capacitors]

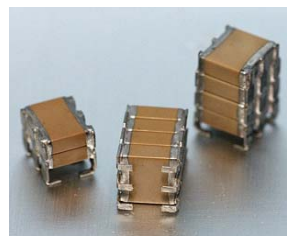

## HMC Series

*MLCC Design, Suitable for High CV Applications that Require Elevated Operating Temperatures*

### ◆ Features

- High temperature ratings (150° through 250° C)
- Stacked design offers the high capacitance similar to Tantalum but with extremely low ESR advantage.
- 'J', 'L' and 'N' Leaded configuration provide mechanical and thermal stress relief.
- Capacitance values up to 8.5μF
- Voltage from 50V to 1000V.
- NP0 and X8R dielectric.
- HIREL screening available.

### ◆ Applications

- Power supplies
- DC-DC converters
- Surge protection
- Industrial control circuits
- Snubbers
- Filtering, smoothing, and decoupling application
- Down-Hole applications
- Under the hood
- Jet engine controls
- Other high operating temperature applications

### ◆ Summary of Specifications

Operating Temperature	-55 to +150 °C, 175 °C, 200 °C, and 250 °C
Rated Voltage	50Vdc to 1000Vdc
Temperature Coefficient of Capacitance	X8R : ≤ ± 15%      -55 to +150 °C (EIA Class II )
	NP0 : ≤ +/- 30 ppm      -55 to 125 °C (EIA Class I)
Capacitance Range	X8R : 14nF to 8.5uF    NP0 : 5.6 nF to 400 nF
Dissipation Factor :	X8R : 2.5%max. at 1KHz    NP0: Q <sub>≥</sub> 1000 at 1KHz
Insulation Resistance	10GΩ or 500/C Ω whichever is smaller
Aging	X8R : 2.5% per decade of time    NP0: negligible
Dielectric Withstanding Voltage	V ≤ 50V                    ; 250% Rated Voltage
	100V ≤ V < 500V ; 200% Rated Voltage
	500V ≤ V < 1KV ; 150% Rated Voltage
	1000V = 120% Rated Voltage
Tolerance	± 5% ~ ± 20% tolerances

### ◆ How To Order



Product Code	Stack and Size	Lead Configuration	Tolerance	Capacitance (pF)	Tolerance	Rated Voltage	Packaging	Marking	Special Requirement
HMC: High temperature Stacked Capacitors	The first digit: # of chips in stack  Second Digit: Chip Size 6: 1812 7: 2220 8: 1825 9: 2225	J :J Lead for h=0.070" L :L Lead for h=0.070" N: Straight Lead P :J Lead for h=0.045" S:L Lead for h=0.045"	Ex.: H: X8R N: NP0	Ex.: 103:10x10 <sup>3</sup> 224:22x10 <sup>4</sup> 475:47x10 <sup>5</sup>	Ex.: J: +/-5.0% K: +/- 10% M: +/- 20%	Ex.: 050: 50Vdc 101: 100Vdc 201: 200Vdc 501: 500Vdc 102:1000Vdc	B: Bulk T:Tape&Reel W: Waffle pack	Ex.: N: No Marking S: Special Marking M: Marked (cap & Tolerance)	Blank: Standard electrical test H: Hi-Rel Testing

◆ Dimensions

J Type

L Type

N Type

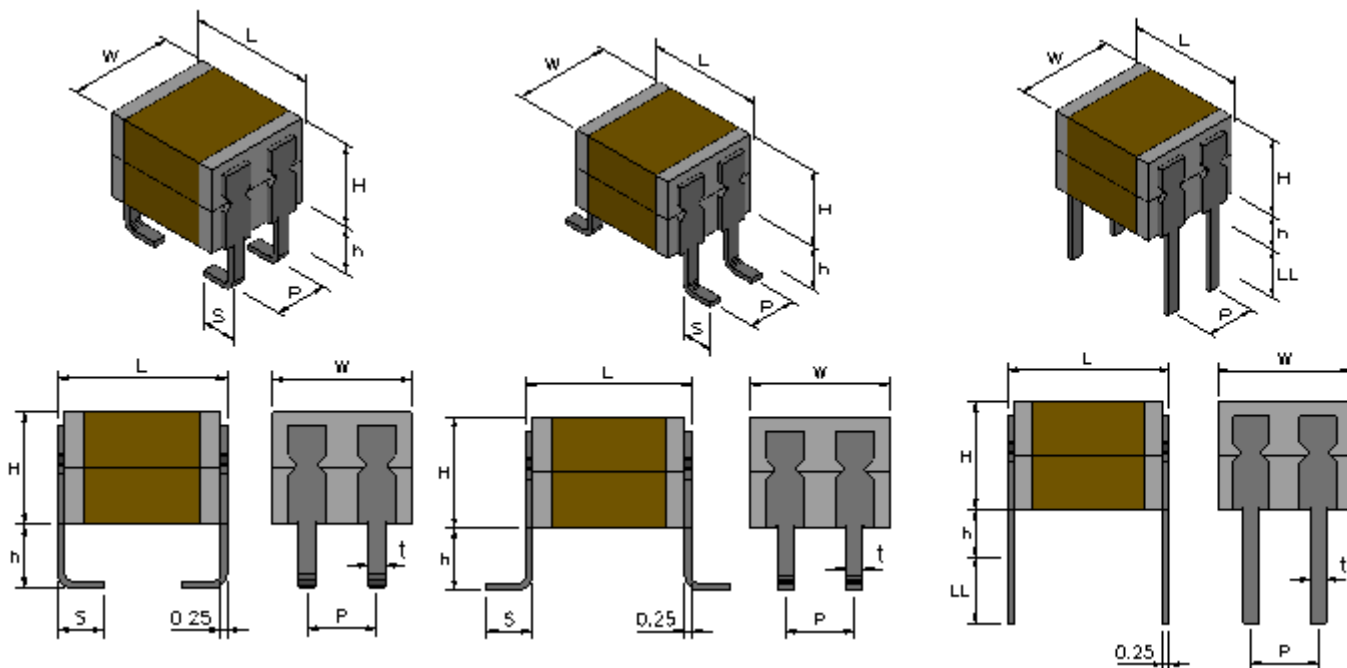

1812 and 2220

J Type

L Type

N Type

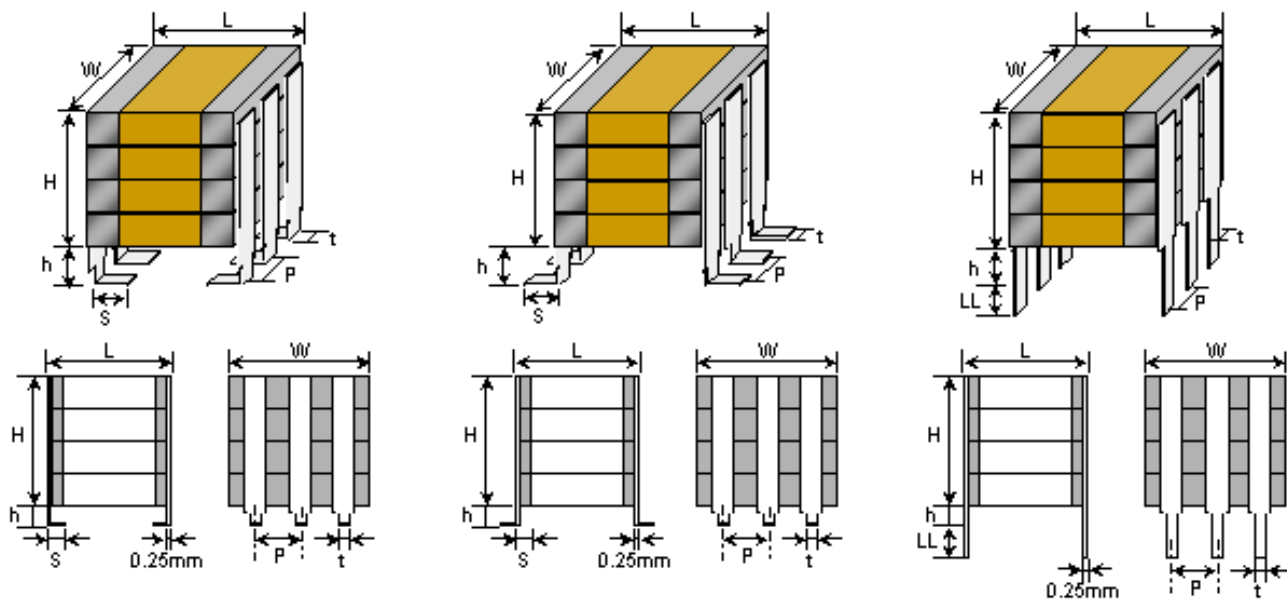

1825 and 2225

Unit : mm [inches]

EIA Size Code	1812			1825			
Size Code	16	26	18	28	38	48	58
L	5.35±0.50 [.210±.020]	5.35±0.50 [.210±.020]	5.35±0.50 [.210±.020]	5.35±0.50 [.210±.020]	5.35±0.50 [.210±.020]	5.35±0.50 [.210±.020]	5.35±0.50 [.210±.020]
W (max.)	3.60 [.142]	3.60 [.142]	6.85 [.270]	6.85 [.270]	6.85 [.270]	6.85 [.270]	6.85 [.270]
H(max.)	2.54 [.100]	5.08 [.200]	2.54 [.100]	5.08 [.200]	7.62 [.300]	10.16 [.400]	12.70 [.500]
S	1.65±0.50 [.065±.020]	1.65±0.50 [.065±.020]	1.65±0.50 [.065±.020]	1.65±0.50 [.065±.020]	1.65±0.50 [.065±.020]	1.65±0.50 [.065±.020]	1.65±0.50 [.065±.020]
P	2.54±0.25 [.100±.010]	2.54±0.25 [.100±.010]	2.54±0.25 [.100±.010]	2.54±0.25 [.100±.010]	2.54±0.25 [.100±.010]	2.54±0.25 [.100±.010]	2.54±0.25 [.100±.010]
h* (Typical)	1.78 [.070]	1.78 [.070]	1.78 [.070]	1.78 [.070]	1.78 [.070]	1.78 [.070]	1.78 [.070]
h* (P/S Type)	1.14 [.045]	1.14 [.045]	1.14 [.045]	1.14 [.045]	1.14 [.045]	1.14 [.045]	1.14 [.045]
LL** (min.)	2.54 [.100]	2.54 [.100]	2.54 [.100]	2.54 [.100]	2.54 [.100]	2.54 [.100]	2.54 [.100]
t	0.50±0.05 [.020±.002]	0.50±0.05 [.020±.002]	0.50±0.10 [.020±.004]	0.50±0.10 [.020±.004]	0.50±0.10 [.020±.004]	0.50±0.10 [.020±.004]	0.50±0.10 [.020±.004]
# of leads per side	2	2	3	3	3	3	3

EIA Size Code	2220			2225			
Size Code	17	27	19	29	39	49	59
L	6.35±0.50 [.250±.020]	6.35±0.50 [.250±.020]	6.35±0.50 [.250±.020]	6.35±0.50 [.250±.020]	6.35±0.50 [.250±.020]	6.35±0.50 [.250±.020]	6.35±0.50 [.250±.020]
W (max.)	6.10 [.240]	6.10 [.240]	6.85 [.270]	6.85 [.270]	6.85 [.270]	6.85 [.270]	6.85 [.270]
H(max.)	2.54 [.100]	5.08 [.200]	2.54 [.100]	5.08 [.200]	7.62 [.300]	10.16 [.400]	12.70 [.500]
S	1.65±0.50 [.065±.020]	1.65±0.50 [.065±.020]	1.65±0.50 [.065±.020]	1.65±0.50 [.065±.020]	1.65±0.50 [.065±.020]	1.65±0.50 [.065±.020]	1.65±0.50 [.065±.020]
P	2.54±0.25 [.100±.010]	2.54±0.25 [.100±.010]	2.54±0.25 [.100±.010]	2.54±0.25 [.100±.010]	2.54±0.25 [.100±.010]	2.54±0.25 [.100±.010]	2.54±0.25 [.100±.010]
h* (Typical)	1.78 [.070]	1.78 [.070]	1.78 [.070]	1.78 [.070]	1.78 [.070]	1.78 [.070]	1.78 [.070]
h* (P/S Type)	1.14 [.045]	1.14 [.045]	1.14 [.045]	1.14 [.045]	1.14 [.045]	1.14 [.045]	1.14 [.045]
LL** (min.)	2.54 [.100]	2.54 [.100]	2.54 [.100]	2.54 [.100]	2.54 [.100]	2.54 [.100]	2.54 [.100]
t	0.50±0.10 [.020±.004]	0.50±0.10 [.020±.004]	0.50±0.10 [.020±.004]	0.50±0.10 [.020±.004]	0.50±0.10 [.020±.004]	0.50±0.10 [.020±.004]	0.50±0.10 [.020±.004]
# of leads per side	2	2	3	3	3	3	3

- \* 'h' varies depends on the lead style. See lead configuration above
- \*\* "LL" Applies only to Straight (N) leads

## ◆ Capacitance Range

EIA Chip Size	Size Code	NPO Maximum Capacitance					X8R Maximum Capacitance				
		50V	100V	200V/250V	500V	1000V	50V	100V	200V/250V	500V	1000V
1812	16 (1×Cap)	293	183	123	822	562	574	454	354	923	143
	26 (2×Cap)	583	363	243	163	113	115	904	704	184	283
2220	17 (1×Cap)	623	543	453	393	123	135	105	804	214	363
	27 (2×Cap)	124	104	903	783	243	265	205	165	424	723
1825	18 (1×Cap)	653	563	473	393	123	135	105	804	214	363
	28 (2×Cap)	134	114	943	783	243	265	205	165	424	723
	38 (3×Cap)	194	164	144	114	363	395	305	245	634	104
	48 (4×Cap)	264	224	184	154	483	525	405	325	844	144
2225	58 (5×Cap)	324	284	234	194	603	655	505	405	105	184
	19 (1×Cap)	813	653	563	473	153	175	145	105	284	493
	29 (2×Cap)	164	134	114	943	303	345	285	205	564	983
	39 (3×Cap)	244	194	164	144	453	515	425	305	844	144
	49 (4×Cap)	324	264	224	184	603	685	565	405	115	194
59 (5×Cap)	404	324	284	234	753	855	705	505	145	244	

■ Other Stacked configurations, sizes, capacitance values and voltages ratings are available. Please contact the factory for details.

### \*Soldering And Handling Precautions:

We recommend reflow soldering for soldering the HMC Series capacitors. Wave soldering and use of manual solder iron processes are to be avoided. For the reflow solder process, all capacitors should be heated to within 50°C and then ramped to peak temperature and back down to within 50°C using a ramp rate of no greater than 2°C per second. Sudden increases or decreases in temperature (more than the recommended rate) may cause thermal cracking. Please note that controlling the rate of cooling is as important as the rate of heating in thermal crack prevention.